

ReechCraft  
**PowerLIFT**<sup>TM</sup>

[www.reechcraft.com/powerlift](http://www.reechcraft.com/powerlift)

**PL60**  
**OPERATOR'S SAFETY MANUAL**

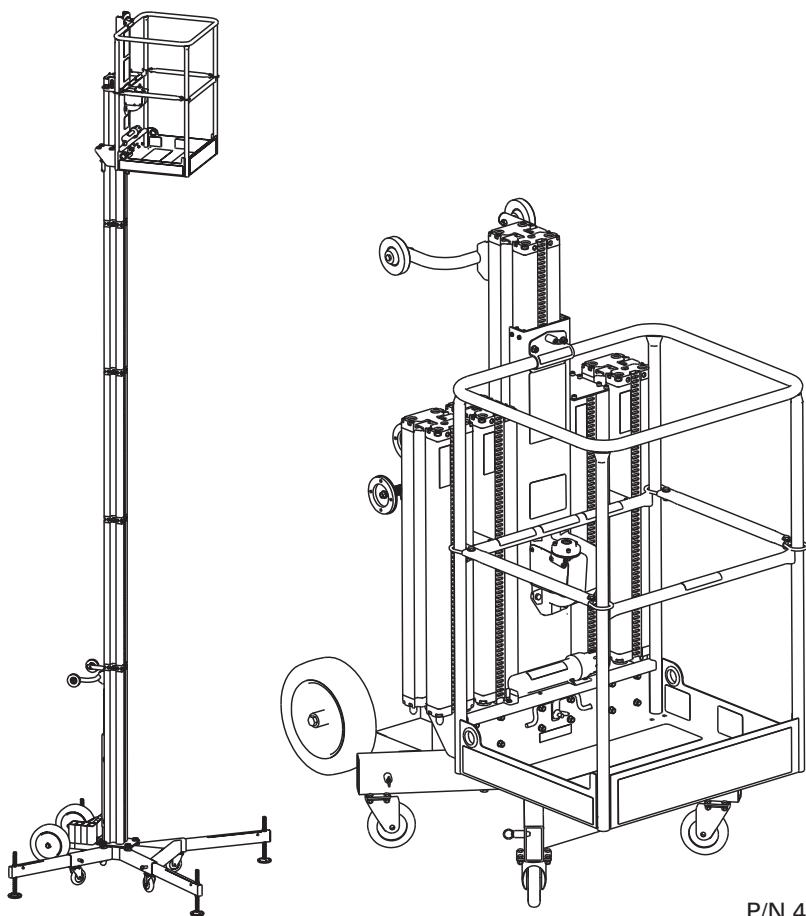

P/N 4026199

**It is very important that you read, understand and obey the contents of this manual! Keep it with the machine at all times.**

The purpose of this manual is to provide safe and proper operating procedures for anyone utilizing the benefits of this machine.

Because we at ReechCraft, Inc. are always working to improve our products, processes and procedures, we reserve the right to make changes without prior notice. Please contact us at ReechCraft for updated information.

## **SAFETY ALERT SYMBOLS AND SAFETY SIGNAL WORDS**



This is the Safety Alert Symbol. It is used throughout this manual and on the machine to alert you to potential personal injury hazards. Understand and obey all safety messages that correspond with this symbol to avoid possible injury or death.



**INDICATES AN IMMINENTLY HAZARDOUS SITUATION AND IF NOT AVOIDED WILL RESULT IN SERIOUS INJURY OR DEATH. THIS DECAL WILL HAVE A RED BACKGROUND.**



**INDICATES A POTENTIALLY HAZARDOUS SITUATION. IF NOT AVOIDED, COULD RESULT IN SERIOUS INJURY OR DEATH. THIS DECAL WILL HAVE AN ORANGE BACKGROUND.**



**INDICATES A POTENTIALLY HAZARDOUS SITUATION THAT IF NOT AVOIDED, MAY RESULT IN MINOR OR MODERATE INJURY. IT MAY ALSO ALERT AGAINST UNSAFE PRACTICES. THIS DECAL WILL HAVE A YELLOW BACKGROUND.**

 **WARNING**

**THIS PRODUCT MUST COMPLY WITH ALL SAFETY RELATED BULLETINS. CONTACT REECHCRAFT, INC. OR THE LOCAL AUTHORIZED REECHCRAFT REPRESENTATIVE FOR INFORMATION REGARDING SAFETY RELATED BULLETINS WHICH MAY HAVE BEEN ISSUED FOR THIS PRODUCT.**

**NOTICE**

**REEHCRAFT, INC. SENDS SAFETY RELATED BULLETINS TO THE OWNER OF RECORD OF THIS MACHINE. CONTACT REECHCRAFT TO ENSURE THAT THE CURRENT OWNER RECORDS ARE UPDATED AND ACCURATE.**

**NOTICE**

**REEHCRAFT MUST BE NOTIFIED IMMEDIATELY IN ALL INSTANCES WHERE OUR PRODUCTS HAVE BEEN INVOLVED IN AN ACCIDENT INVOLVING BODILY INJURY OR DEATH OF PERSONNEL OR WHERE SUBSTANTIAL PERSONAL PROPERTY DAMAGE OR DAMAGE TO THE REECHCRAFT PRODUCT HAS OCCURRED.**

**FOR:**

- **Accident Reporting**
- **Product Safety Publications**
- **Current Owner Updates**
- **Product Safety Questions**
- **Standards and Regulations Compliance Information**
- **Questions Regarding Special Applications**
- **Questions Regarding Product Modifications**

**CONTACT:**

**Technical Safety and Engineering Department**  
845 34th St N  
Fargo, ND 58102

E-mail: [customer.service@reechcraft.com](mailto:customer.service@reechcraft.com)

**In USA**

Toll Free: 888-600-6160

**Outside USA**

Phone: 701-280-5900

# REVISION LOG

Updated Version of Manual .....	April 2, 2019 v 1.1
Original Version of Manual .....	May 6, 2013 v 1.0

# TABLE OF CONTENTS

## SECTION - INFORMATIONAL

FOREWORD.....	2
SAFETY ALERT SYMBOLS AND SAFETY WORDS .....	2-3
CONTACT .....	3
REVISION LOG .....	4

## SECTION - 1 - SAFETY PRECAUTIONS..... 8

1.1 GENERAL.....	8
1.2 PRE-OPERATION.....	8
Operator Preparedness .....	8
Work Site Inspection.....	9
Machine Inspection.....	9
1.3 OPERATION.....	10
General .....	10
Fall Hazards .....	10
Electrocution Hazard .....	11
Tipping Hazards.....	12
Crushing and Collisions Hazards.....	14
1.4 MANEUVERING, TRANSPORTING AND LIFTING.....	15
General .....	15
Additional Safety Information .....	15

## SECTION - 2 - PREPARATION AND INSPECTION ..... 16

2.1 PERSONNEL REQUIREMENTS .....	16
Operator Requirements.....	16
Operator Responsibilities.....	16
2.2 PREPARATION, INSPECTION AND MAINTENANCE .....	17
Pre-Start Inspection .....	17
2.3 DAILY WALK-AROUND INSPECTION .....	18
Walk-Around Inspection Components .....	19
2.4 FUNCTION CHECK.....	24
Function Check Items .....	24

**SECTION - 3 - MACHINE OPERATION ..... 26**

3.1 GENERAL..... 26

3.2 MACHINE DESCRIPTION..... 26

    Stowed Machine ..... 26-27

    Drill Motor ..... 28

3.3 MACHINE OPERATION ..... 29

    General ..... 29

3.4 MACHINE SET UP..... 30

    Getting Started..... 30

    Elevating..... 31

    Joining Mast Sections ..... 32

    Separating Mast Sections ..... 33

    Unpowered Descent ..... 33

3.5 MANEUVERING AND TRANSPORT ..... 34

    General ..... 34

    Upright Maneuvering ..... 34

    Tilted Over Maneuvering ..... 34

    Parking and Storage ..... 36

    Vehicle Transport ..... 36

**SECTION - 4 - EMERGENCY PROCEDURES ..... 37**

4.1 GENERAL INFORMATION ..... 37

    Manual Descent Crank ..... 37

    Discharged Battery or Loss Of Power ..... 38

    Operator Unable to Control the Machine ..... 39

    Platform Caught Overhead ..... 40

4.2 INCIDENT NOTIFICATION ..... 40

**SECTION - 5 - GENERAL SPECIFICATIONS ..... 41**

5.1 INTRODUCTION ..... 41

5.2 DECAL CONTENTS AND LOCATION ..... 41-44

5.3 SPECIFICATIONS ..... 45

    Machine Specifications ..... 45

<b>SECTION - 6 - SERVICE AND MAINTENANCE</b> .....	<b>47</b>
6.1 MAINTENANCE SAFETY PRECAUTIONS .....	47
General .....	47
Maintenance Safety .....	48
6.2 MACHINE PREPARATION, INSPECTION AND MAINTENANCE .....	49
General .....	49
Preparation, Inspection and Maintenance .....	49
Pre-Start Inspection .....	49
Frequent and Pre-Delivery Inspection.....	49
Annual Machine Inspection .....	50
5 year Inspection and Track Replacement .....	50
6.3 PREVENTIVE MAINTENANCE AND INSPECTION SCHEDULE .....	51
Inspection and Maintenance Codes .....	51
6.4 SERVICING AND MAINTENANCE GUIDELINES.....	53
General .....	53
Safety and Workmanship .....	53
Cleanliness .....	53
Component Disassembly and Reassembly .....	53
6.5 DECAL REPLACEMENT .....	54
6.6 MASTTRACK INSPECTION PROCEDURE .....	54
Mast Track Wear.....	55
Mast Track Misalignment .....	55
Mast Connector Wear .....	55
Machine Log.....	56
<b>SECTION - 7 - TROUBLESHOOTING</b> .....	<b>57</b>
7.1 GENERAL .....	57
Troubleshooting Information.....	57

**LIST OF FIGURES**

1-1. Read your manual.....8

2-1. Inspection Points..... 19

2-2. Chassis/Bubble Level .....20

2-3. Climbing Unit.....21

2-4. Maximum Track Wear .....22

2-5. Location of Manual Descent Crank .....22

2-7. Platform Mounting and Retaining Pins .....24

2-8. Mast Connectors .....25

3-1. Fully Stowed Machine ..... 26-27

3-2. Typical Drill Motor.....28

3-3. Proper Set Up.....30

3-4. Bubble Level .....31

3-5. Drill Motor Operation/Elevating .....31

3-6. Joining Mast Sections.....32

3-7. Separating Mast Sections.....33

3-8. Maneuvering When Tilted Back .....35

4-1. Manual Descent Crank Operation.....38

4-2. Emergency Retraction System .....39

5-1. Chassis/Base Mast Decal Locations .....42

5-2. Climbing Unit Decal Locations .....42

5-3. Platform Decal Locations .....43

5-4. Outrigger Decal Locations .....44

5-5. Machine Specifications .....46

6-1. Mast/Track Alignment .....55

**LIST OF TABLES**

1-1. Minimum Approach Distances (M.A.D.)..... 11

2-1. Inspection and Maintenance..... 18

5-1. Decal Contents and Location .....41

5-2. Machine Specifications .....45

6-1. Preventive Maintenance and Inspection Schedule .....52

7-1. Troubleshooting Guide.....58

# SECTION 1

## SAFETY PRECAUTIONS

### 1.1 General

This section is the starting point for establishing habitual precautions for safe operation of the machine. This manual is your guide in developing a daily routine that focuses on safety and proper maintenance of the machine prior to each use. A maintenance program must be established and conducted by a qualified person to ensure the machine is in safe working condition before it is operated.

**Before operating the machine, the operator shall:**

1. Read, understand and obey the operating instructions and safety rules in this manual.
2. Obey all labels, warnings and instructions located on the machine.
3. Be sure that all occupants of the machine wear appropriate personal protection equipment (PPE) for the conditions.

If there are any questions regarding safety, training, maintenance, inspection, application or operation of the machine, please contact ReechCraft.



**FAILURE TO COMPLY WITH THE SAFETY PRECAUTIONS LISTED IN THIS MANUAL COULD RESULT IN MACHINE DAMAGE, PROPERTY DAMAGE, PERSONAL INJURY OR DEATH.**

### 1.2 Pre-Operation

#### Operator Preparedness



Figure 1-1 Read your manual

- Do not operate this machine until the operator has read and fully comprehends the Operator's Safety Manual of the machine.
- Only competent personnel may operate the machine.
- Read, fully comprehend and obey all DANGERS, WARNINGS, CAUTIONS and operating instructions on the machine and in this manual.
- Only use this machine in a manner which is within the scope of the intended application set by ReechCraft.



- All operating personnel must be familiar with the emergency procedures and controls specified in this manual
- All operating personnel must read, comprehend and obey all applicable employer, local and governmental regulations as they pertain to the safe operation of the machine.

### Work Site Inspection

- The operator is to take measures to identify and avoid all hazards in the work area that will affect the safe operation of the machine.
- Do not elevate unless all tools, equipment and materials can be safely stowed within the platform.
- Machine can be operated in ambient air temperature of -20°F to 135°F (-29°C to 57°C). Consult ReechCraft for operation outside of this range. Machine performance may be affected in very hot or cold conditions.

### Machine Inspection

- Before machine operation, perform walk around inspections and function checks. Refer to Section 2 of this manual for further instructions.
- No one shall operate the machine until it has been inspected, serviced and maintained according to the requirements in this manual.



### **MODIFICATION OR ALTERATION OF MACHINE SHALL BE MADE ONLY WITH PRIOR WRITTEN PERMISSION FROM THE MANUFACTURER**

- Do not operate any machine on which the safety decals or instruction placards are missing or illegible.
- Avoid any build up of debris on platform floor. Keep mud, oil, grease and other slippery substances from footwear and the platform floor.

## 1.3 Operation

### General

- Do not use the machine for any purpose other than positioning personnel, their tools, equipment and materials.
- Never operate a machine that is not working properly. If a malfunction occurs, shut down the machine and contact ReechCraft.
- Unless in an emergency, do not allow personnel to tamper with, or operate the machine from the ground with personnel on the platform.
- The operator will not elevate the platform unless the bearing surface is stationary and capable of supporting the intended load.
- Always ensure that power tools are properly stowed and never left suspended by their cord from the platform.
- Be sure to fully lower the platform completely and shut off all power before leaving the machine.
- No more than one person is allowed on the machine. Only the operator is permitted in the platform during operation.

### Fall Hazards

- Do not enter or leave the platform while elevated.
- Before operating the machine, make sure all mast sections, outriggers, railings and gates are in their proper position. Be sure the platform is properly secured to the climbing unit before operating the machine.
- Keep both feet firmly positioned on the platform floor at all times. Never use ladders, boxes, steps, planks or any other item on the platform to provide additional height for greater reach.
- Never use the mast or railings to enter or leave the platform.



- Always use extreme caution when entering or exiting the platform. Be sure that the platform is fully lowered before exiting the platform.
- Always maintain three points of contact with the machine. "3 point contact" means using two hands and one foot or two feet and one hand at all times while entering or exiting the platform.

## Electrocution Hazard

- This machine is not insulated and will not provide protection from contact or proximity to electrical current.
- Maintain distance from electrical lines, apparatus or any energized (exposed or insulated) parts according to the Minimum Approach Distance (MAD) as shown in Table 1-1.
- Allow clearance for machine movement and electrical line swaying.

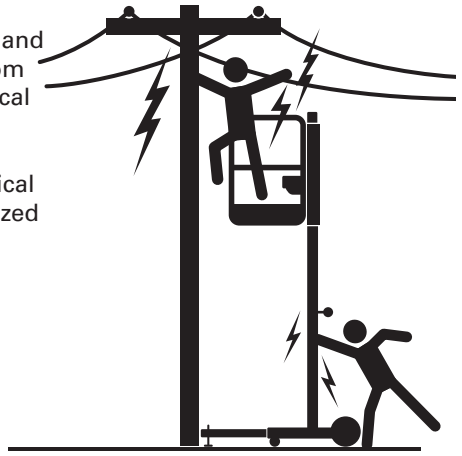

**Table 1-1** Minimum Approach Distances (M.A.D.)

VOLTAGE RANGE (PHASE TO PHASE)	MINIMUM SAFE APPROACH DISTANCE - FEET (METERS)
0-50KV	10 (3)
Over 50KV to 200KV	15 (5)
Over 200KV to 350KV	20 (6)
Over 350KV to 500KV	25 (8)
Over 500KV to 750KV	35 (11)
Over 750KV to 1000KV	45 (14)

**NOTE:** This requirement shall apply except where employer, local or governmental regulations are more stringent.

## SAFETY PRECAUTIONS

- Maintain a clearance of at least 10 ft (3 m) between any part of the machine and its occupants, their tools and their equipment from any electrical line or apparatus carrying up to 50,000 volts. 1 ft (.3 m) additional clearance is required for every additional 30,000 volts or less.
- The minimum safe approach distance may be reduced if insulating barriers are installed to prevent contact, and if the barriers are rated for the voltage of the line being guarded. These barriers shall not be part of (or attached to) the machine. The minimum safe approach distance shall be reduced to a distance within the designed working dimensions of the insulating barrier. This determination shall be made by a qualified person in accordance with employer, local or governmental requirements for work practices near energized equipment.



**DO NOT MANEUVER MACHINE OR PERSONNEL INSIDE PROHIBITED ZONE (MAD). ASSUME ALL ELECTRICAL PARTS AND WIRING ARE ENERGIZED UNLESS KNOWN OTHERWISE.**

### Tipping Hazards

- Be sure the bearing surface is solid, stationary and capable of supporting the intended load.
- Before entering the platform, ensure that all outriggers have been properly installed and all leveling jacks are fully extended and bearing weight.
- Check to be sure the chassis is level according to the bubble level indicator on the chassis and all wheels are completely off the ground. Note: the platform will not release from its docked position unless each outrigger is in its proper position, fully extended and bearing weight.

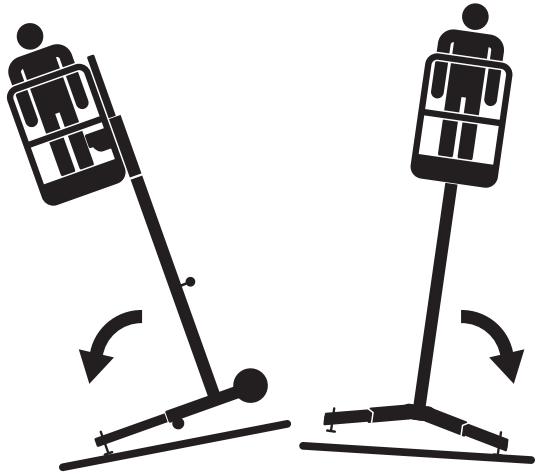

- Do not perform work that will subject the machine to a horizontal force or create a swaying motion of the platform.
- The user should be familiar with the operating surface. If there is a question related to the stability of the ground condition, an appropriate sill should be used to safely spread the load of the machine and rated load capacity.
- Do not elevate the platform on a slope greater than what can be leveled and kept from sliding by the outrigger leveling jacks and an appropriate sill.
- Do not elevate if there is a safety concern related to the stability of the bearing surface.
- Before using the machine on floors, bridges, and other surfaces, check allowable capacity of the surfaces.
- Never exceed the maximum platform capacity. Distribute loads evenly on platform floor.
- Keep the bearing pads of the outriggers a safe distance from holes, bumps, drop-offs, obstructions, debris, concealed holes and other potential hazards at the ground level.
- Never attempt to use the machine as a crane. Do not tie off machine to any adjacent structure.
- Do not increase the platform size or height with unauthorized extensions, attachments or steps, as personnel movement or added height will decrease stability.
- If the mast or platform is caught so that one or more of the outrigger bearing pads are off the ground, the operator must be removed before attempting to free the machine.

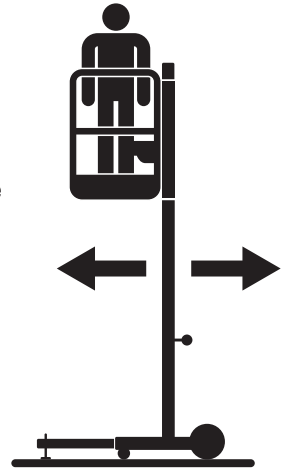

## Crushing and Collision Hazards

- Appropriate personal protection equipment must be worn by all operating and ground personnel.
- Check work area clearances above, on sides and below platform while moving, elevating or lowering platform.
- Be sure to keep all body parts inside the platform railing during operation.
- Exercise extreme caution at all times to prevent obstacles from striking or interfering with operating controls (drill) and persons in the platform.
- Ensure that operators of other overhead and floor level equipment or machines are aware of the machines presence. Disconnect power to overhead cranes.
- Warn personnel not to work, stand or walk under an elevated platform. Position barricades on the floor as necessary.

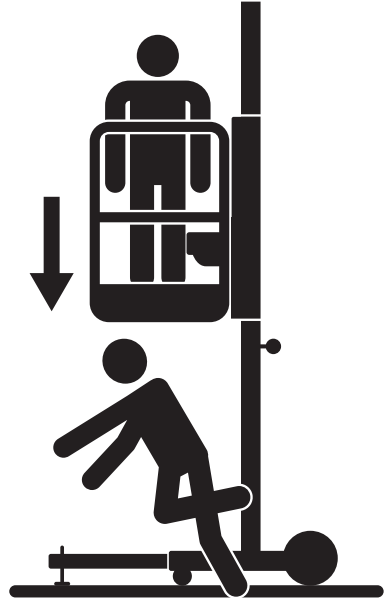

## 1.4 Maneuvering, Transporting & Lifting

### General

- Never allow personnel in the platform while moving, lifting or repositioning the machine.
- This machine shall not be towed by a vehicle.
- Be sure the platform is fully lowered and outriggers and mast sections are properly stowed before tilting back for rough terrain transport.
- Remove drill, tools and equipment from platform when transporting in a vehicle.
- Refer to the Machine Operation section of this manual for lifting information.

### Additional Safety Information

- Platform must be fully lowered before outriggers can be safely removed.
- Do not use machine as a ground for welding.
- Do not attempt to transport assembled machine by forklift.
- Be sure to lock two or more of the casters before leaving the machine unattended.
- Use extreme caution when transporting the machine on a slope in the upright position.

# SECTION 2

## PREPARATION & INSPECTION

### 2.1 Personnel Requirements

This Machine is intended to be used as a personnel handling device and must be operated and maintained by competent personnel only.

Anyone under the influence of drugs, alcohol or are subjected to bouts of dizziness, seizures or loss of physical control must not operate this machine.

#### Operator Requirements

Before operating this machine, the operator must read and comprehend this manual.

**The operator must be familiar with:**

1. Use and limitations of the components of the machine including the specification requirements of the drill motor.
2. Instruction placards and warning decals on the machine and in this manual.
3. Employer and government regulations.
4. Use of approved fall protection device (where applicable).
5. Sufficient mechanical aptitude and knowledge of the machine to recognize a component malfunction or a potential malfunction.
6. The safest means to operate the machine where overhead and ground hazards are present. These hazards include: overhead obstructions, additional moving equipment, obstacles, depressions, drop-offs, etc.
7. A means to avoid unprotected electrical conductors.
8. The specific job requirements.

#### Operator Responsibilities

The exercise of good judgment, safety control, and caution in evaluating each situation is the responsibility of the Operator. The Operator must shut down the machine in the event of a malfunction or other unsafe condition of the machine or job site.



## 2.2 Preparation, Inspection & Maintenance

### Pre-Start Inspection

The Pre-Start Inspection should include each of the following:

1. **Cleanliness** - Check all surfaces for leakage, debris or foreign objects.
2. **Decals and Placards** - Check for cleanliness and legibility. Make sure none of the decals or placards are missing. Make sure all illegible decals are cleaned or replaced. (Reference Section 5.2 Decal Contents and Location)
3. **Safety, Service** - Make sure a copy of the Operator's and Safety manual is enclosed in a weather resistant container.
4. **Set-Up** - Make sure the machine is set-up in accordance with Section 3.4.
5. **Walk-Around Inspection** - Refer to Section 2.3.
6. **Drill Selection Criteria** - Refer to Section 3.2.
7. **Function Check** - Once the Walk-Around Inspection is complete, perform a function check of all systems in an area free of all over-head or ground level obstructions. Refer to Section 2.4 for additional information.

The following table outlines the periodic machine inspection and maintenance recommended by ReechCraft. Consult local regulations for further requirements.

The frequency of inspections and required maintenance must be increased if the machine is exposed to harsh conditions, increased use or if the machine is used in a severe manner.

**Table 2-1** Inspection and Maintenance

TYPE	FREQUENCY	PRIMARY RESPONSIBILITY	SERVICE QUALIFICATION	REFERENCE
Pre-start Inspection	Before starting each day or at shift change	Operator	User or Operator	Operator's and Safety Manual
Frequent Inspection	In service or out of service for 3 mo. Or purchased used	Owner, Dealer or User	Qualified Mechanic*	Operator's and Safety Manual
Annual Machine Inspection	Every 12 Months	Owner, Dealer or User	Qualified Mechanic*	Operator's and Safety Manual
Replacement	When Track is worn or damaged	Owner, Dealer or User	Qualified Mechanic*	Operator's and Safety Manual

**NOTE:** Use this manual to perform inspections

**NOTE:** \*A person who has acquired training, qualifications or a combination of these, the knowledge and skill enabling the person to inspect and repair the machine to the level required by the complexity of the task.

## 2.3 Daily Walk-Around Inspection

Begin the Daily Walk-Around Inspection starting at item one (1) as noted on the diagram Figure 2-1. Continue around the machine checking each item in sequence for the conditions listed in the following check list.



**TO AVOID POSSIBLE INJURY MAKE SURE THERE IS NO POWER SUPPLIED TO THE MACHINE DURING THE WALK AROUND INSPECTION DO NOT OPERATE MACHINE UNTIL ALL MALFUNCTIONS HAVE BEEN CORRECTED.**

**NOTE:** Do not overlook the underside of the chassis. Check this area for corrosion, debris and cracks.

**NOTE:** The Mast and Climbing Unit should be clean and free of grease, oil and dirt. Do not lubricate the Mast or Climbing Unit components.

### Walk-Around Inspection Components

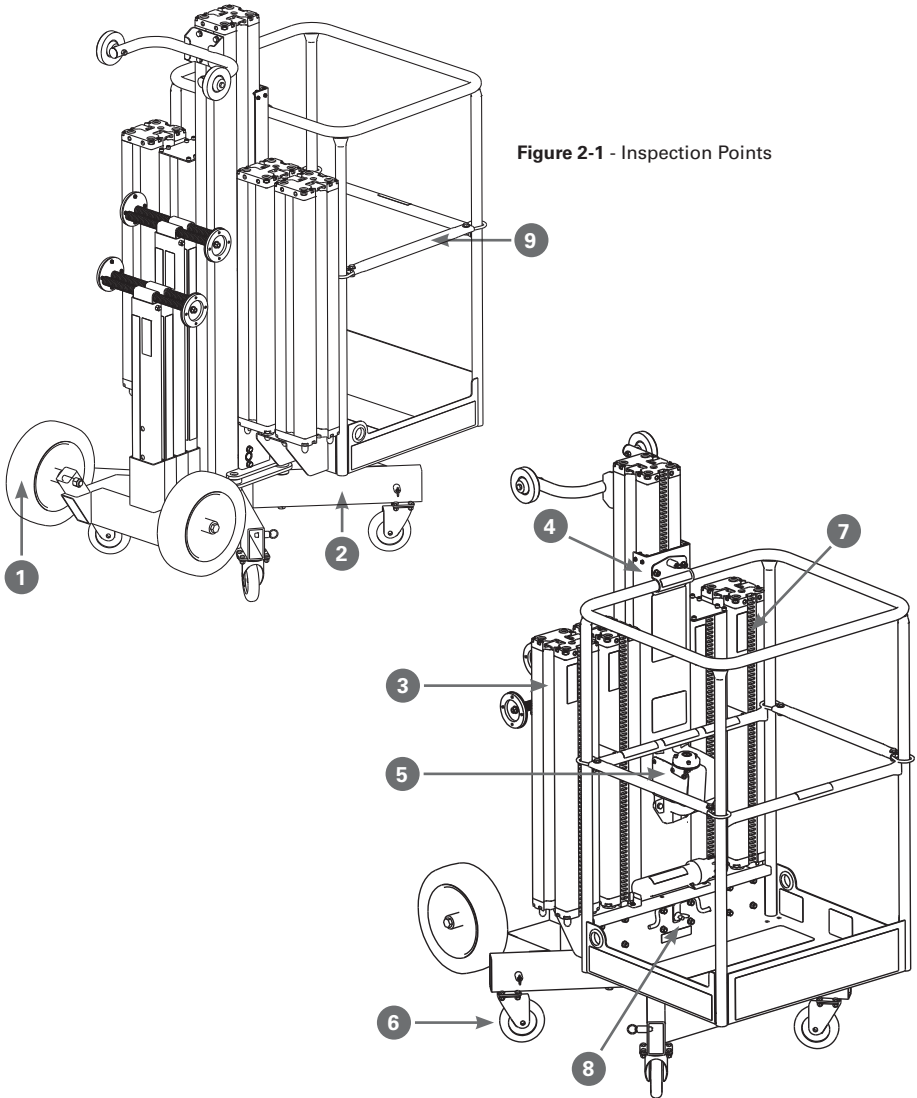

Figure 2-1 - Inspection Points

## PREPARATION &amp; INSPECTION

**NOTE:** On all components, make sure there are no loose or missing parts and that everything is securely fastened. Make sure that there is no visible damage or excessive wear.

1. **Rear Wheels** - Check for any debris stuck to or around the wheel or axle. Make sure the axle bolts are tight and that the wheel spins freely.
2. **Chassis** - Check for cracks or corrosion especially at intersecting weld joints. Make sure Bubble Level is clean and functioning. Be sure all four outrigger pins are functioning properly. (See Figure 2-2)
3. **Mast Sections** - Check for cracks and corrosion. Make sure the Cam Levers are not bent or misshapen and springs are functioning properly. Make sure the track teeth are not worn, bent or misshapen. Make sure the Cam Lever Lock is not bent or misshapen and the spring is functioning properly. Make sure the Connector Pins are not worn or damaged and the Connector Pin Openings are clean and free of debris. Check to be sure the Cam Lever Shaft is not showing excessive wear. (See Figures 2-1, 6-1 and 2-4)
4. **Climbing Unit** - Check for visible cracks or corrosion. Check guide rollers for visible wear and proper alignment. Check to be sure all fasteners and interlock pins are tight and functioning properly. (See Figure 2-3)

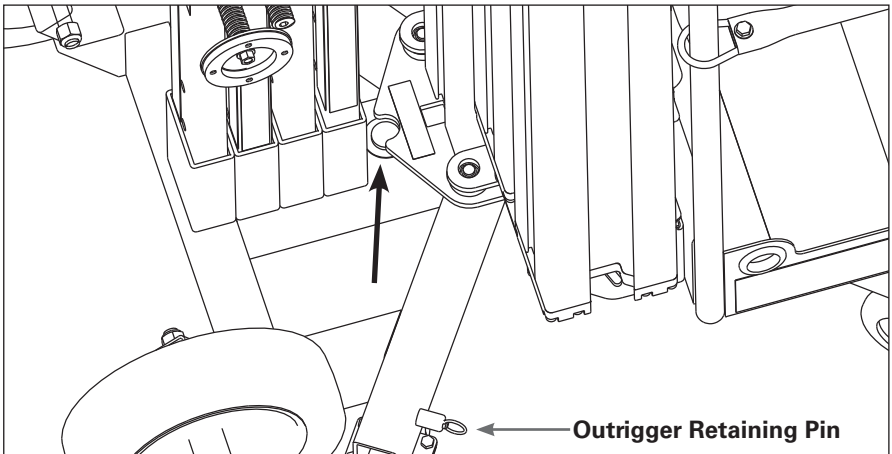
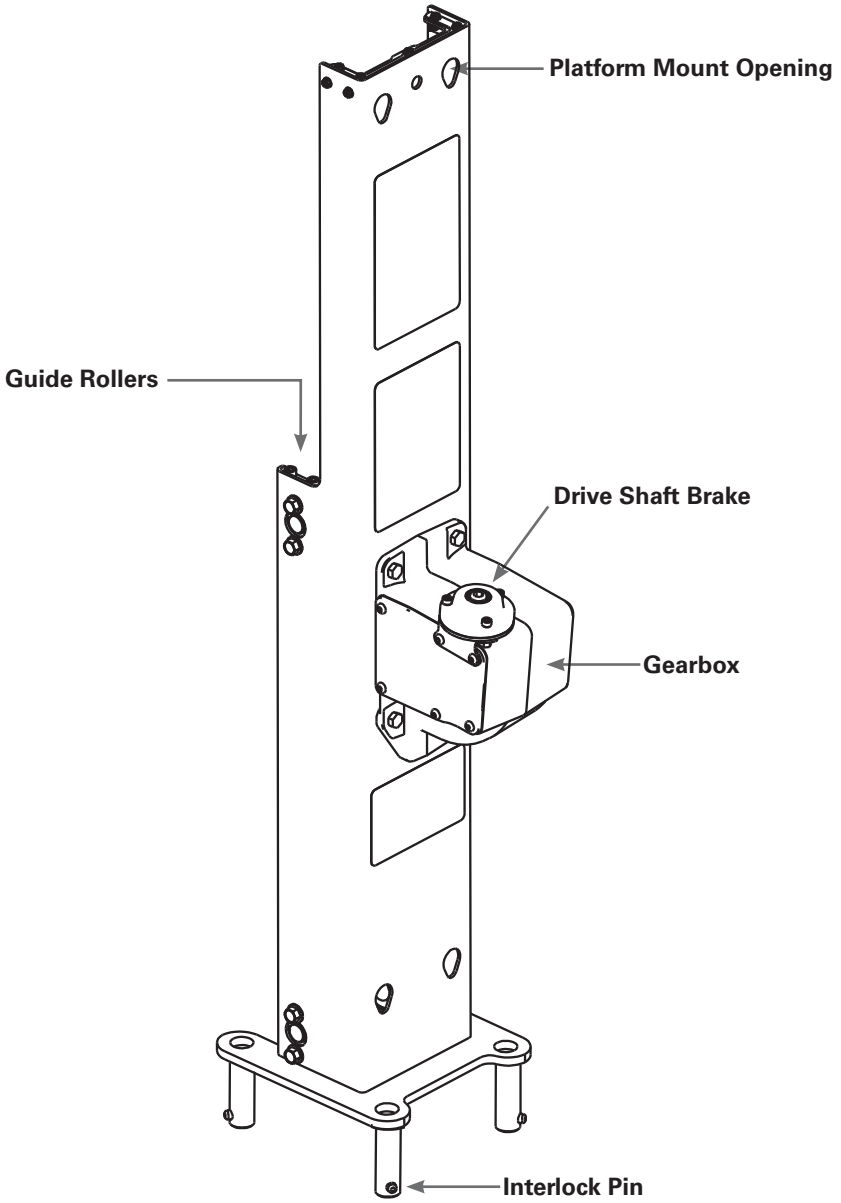

Fig 2-2 - Bubble Level

Figure 2-3 - Climbing Unit



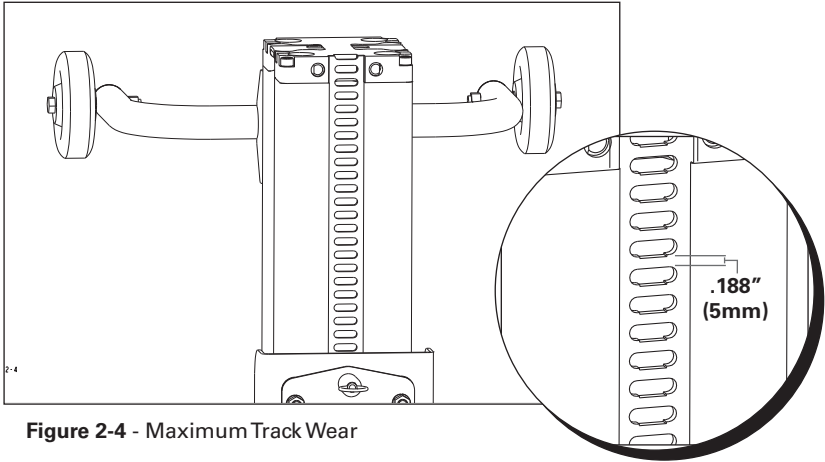

Figure 2-4 - Maximum Track Wear

- 5. Gearbox** - Check for any oil leaks and make sure the Drive Shaft Brake is functioning properly by pressing down on the hex shaft. The hex shaft should return to the up position freely without excessive side movement.
- 6. Swivel Casters** - Check for any debris stuck to or around the wheels or swivel mechanism. Check to be sure the lock is in good working condition and that the wheels are functioning properly.
- 7. Track Sections** - Check that the teeth of all the track sections are not excessively worn (.188" (5mm) tooth remaining), bent, misshapen or missing. (See Figure 2.4)

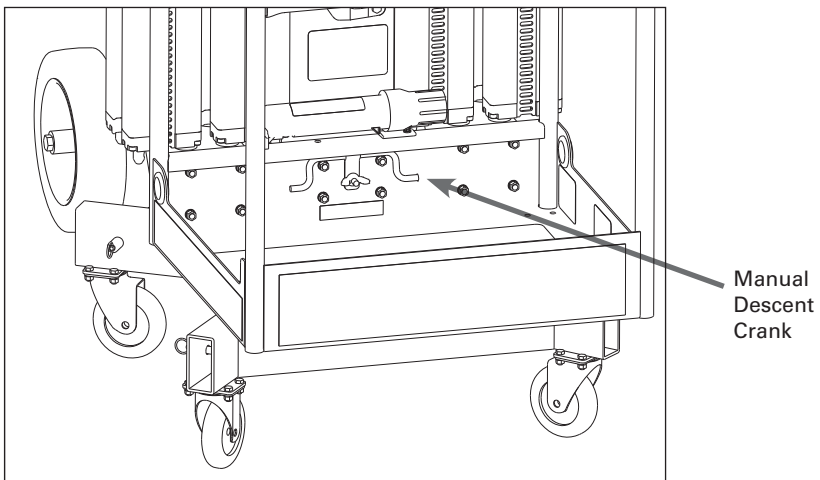

Figure 2-5 - Location of Manual Decent Crank

8. **Manual Decent Crank** - Check to be sure it is present and securely attached (See Figure 2-5)
9. **Platform and Entry Gate** - Check to be sure that the mounting pins are not loose; platform railing is undamaged; platform retaining pin is functioning properly; self closing slide gates are functioning properly; no cracks or visible corrosion present. (See Figure 2-6)

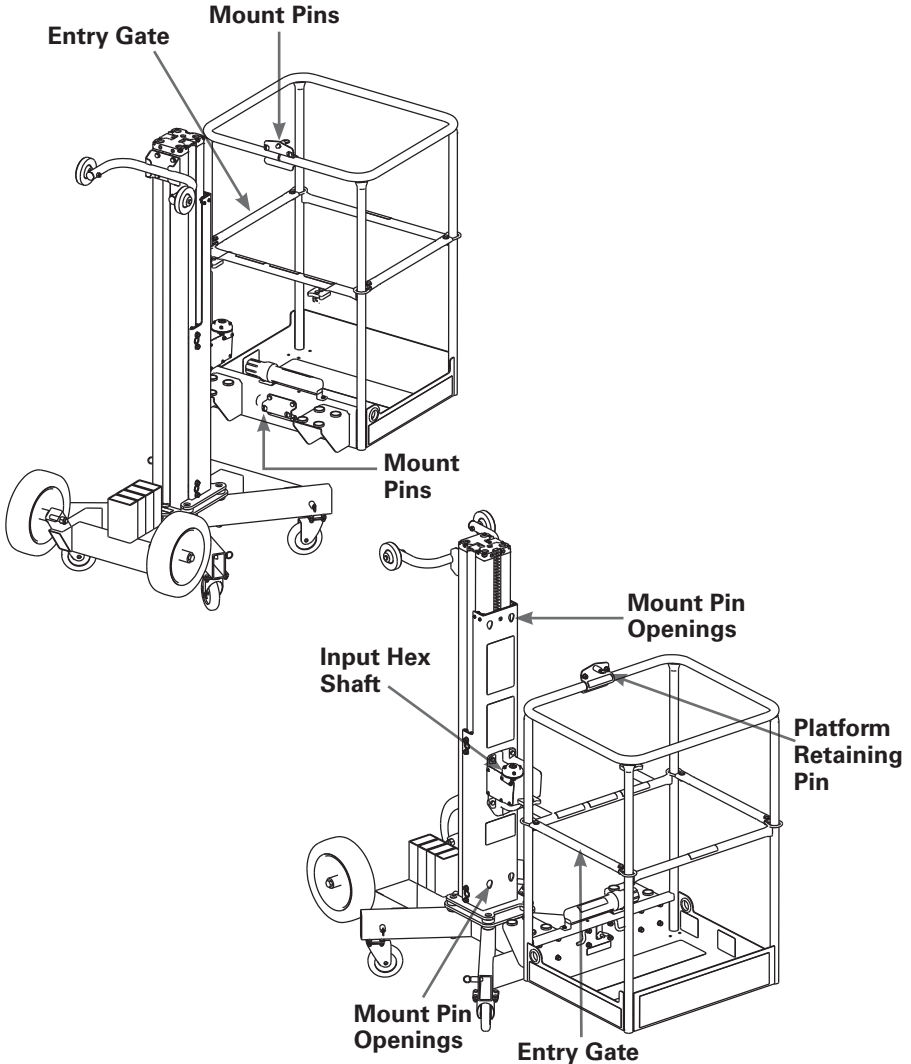

Figure 2-6 - Platform Mounting and Retaining Pins

## 2.4 Function Check

Once the Walk-Around Inspection check is complete, perform a function check of all systems in an area free of overhead and ground level obstructions.



**IF THE MACHINE DOES NOT OPERATE PROPERLY, SHUT OFF AND REMOVE POWER FROM THE MACHINE IMMEDIATELY! REPORT THE PROBLEM TO THE PROPER MAINTENANCE PERSONNEL AND DO NOT OPERATE THE MACHINE UNTIL IT HAS BEEN DEEMED SAFE FOR OPERATION.**

### Function Check Items

1. **Drive Shaft Brake** - Check to be sure the input hex shaft plunges properly and returns to its properly seated position. The input hex shaft should be firmly seated in its return position and resist turning freely in either direction.
2. **Overload Clutch** - Check to be sure the Overload Clutch is functioning properly by briefly running the drill motor in the reverse direction (counterclockwise). You should hear and audible buzzing sound.  
**NOTE:** *Be sure to maintain a firm grip on the drill.*
3. **Outrigger Interlock** - Check to be sure the Outrigger Interlock is functioning properly by briefly running the drill motor in the forward position (clockwise) with the outriggers removed. The platform should not disengage from its fully lowered position and you should hear an audible "buzzing" sound coming from the overload clutch slipping.  
**NOTE:** *Be sure to maintain a firm grip on the drill.*
4. **Mast Connectors** - Check to be sure the components of the Mast Connectors are present, undamaged, clear of debris and in good working condition. (See Figure 2-7) **NOTE:** *Be sure the top mast Termination Plate is present, undamaged and securely attached to the mast section.*



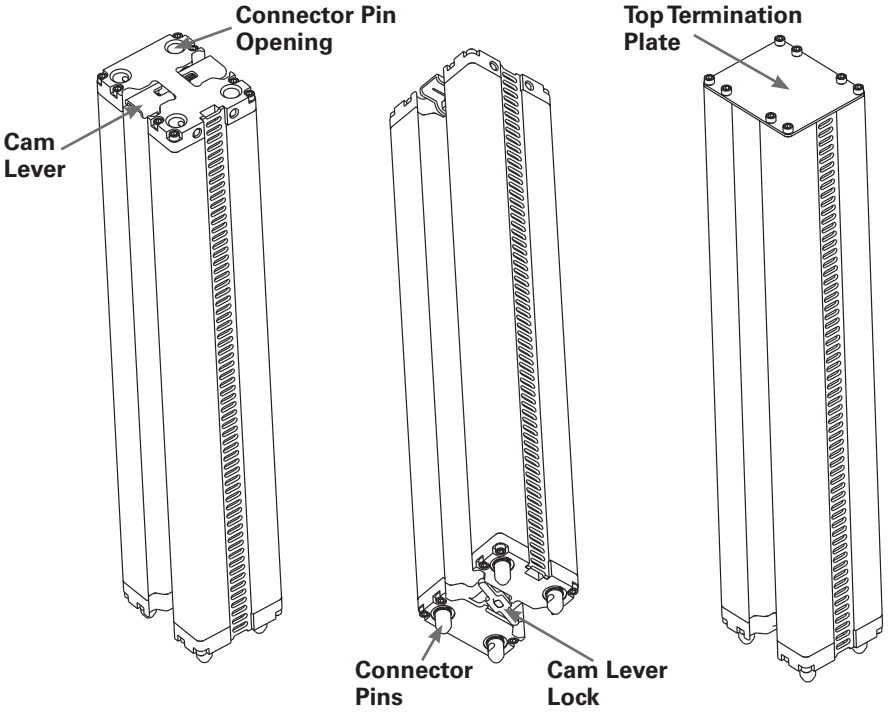

Figure 2-7 - Mast Connectors

# SECTION 3

## MACHINE OPERATION

### 3.1 General

**NOTE:** The manufacturer has no direct control over the machine application and operation. The operator is responsible for following sound safety practices.

### 3.2 Machine Description

The ReechCraft PowerLift is a drill powered aerial work platform (AWP). The removable platform is mounted to an elevating climbing unit that combines up to four (4) modular mast sections that are stacked and fixed to a base mast on a movable chassis. The machine is stabilized by way of outriggers and leveling jacks. The PowerLift's intended purpose is to provide personnel and their tools access to work areas above the ground.

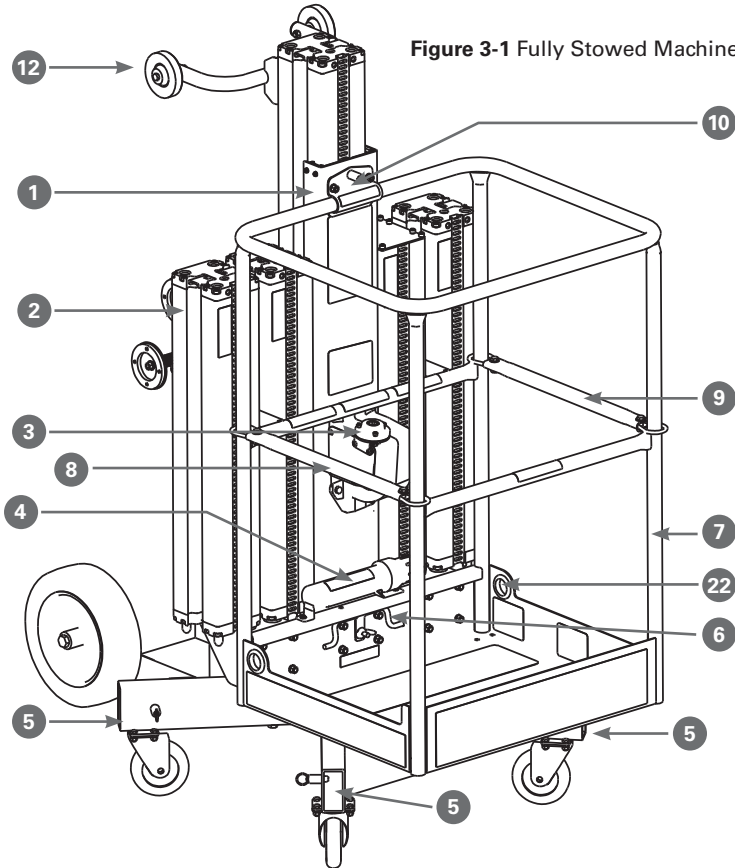

Figure 3-1 Fully Stowed Machine (1 of 2)

**Legend**

- |                                |                                       |
|--------------------------------|---------------------------------------|
| 1. Climbing Unit               | 13. Outrigger Retaining Pin           |
| 2. Intermediate Mast           | 14. Top Mast                          |
| 3. Drive Shaft Brake           | 15. Front Outrigger                   |
| 4. Manual Container            | 16. Leveling Jack                     |
| 5. Outrigger Socket            | 17. Rear Outrigger                    |
| 6. Manual Descent Crank        | 18. All Terrain Transport Tire        |
| 7. Platform                    | 19. Outrigger Storage Socket          |
| 8. Gearbox                     | 20. Bubble Level                      |
| 9. Platform Entry Gate         | 21. Chassis                           |
| 10. Platform Retaining Pin     | 22. Anchor Point/Ext. Cord Throughway |
| 11. Tilt-back handle           |                                       |
| 12. Horizontal Transport Wheel |                                       |

The primary control of the machine is the drill motor.

**NOTE:** Be sure to follow the recommended drill motor specifications for safe operation and best machine performance.

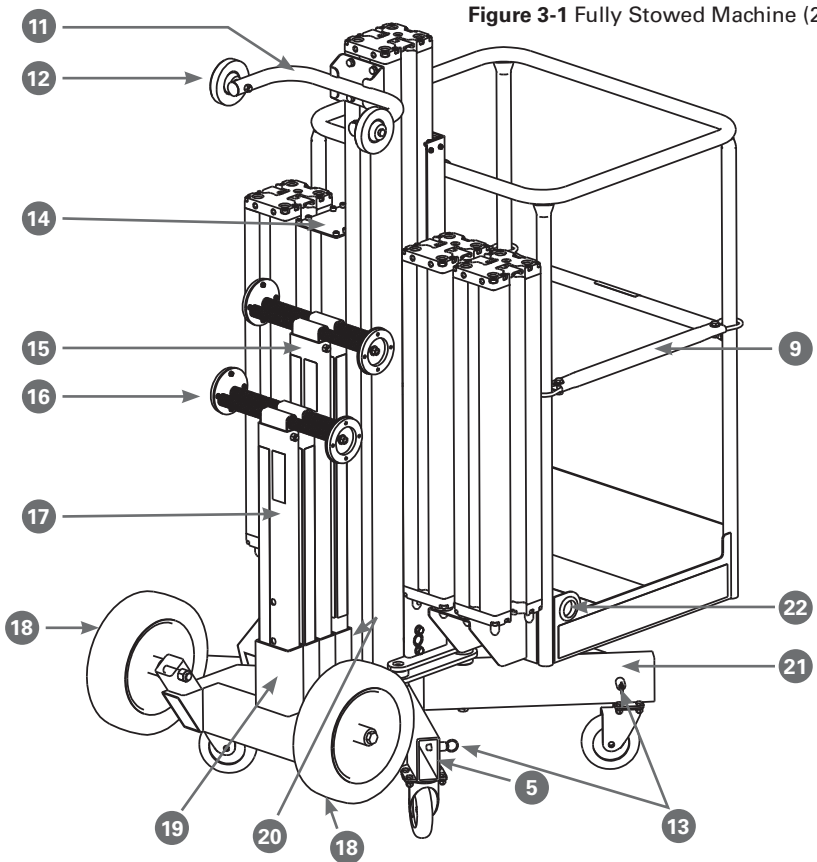

**Figure 3-1 Fully Stowed Machine (2 of 2)**

## Drill Motor

ReechCraft recommends a cordless drill of at least 18V capacity or a corded drill of at least 7 amps.

Ensure the drill motor's optional "Hammer" setting is disabled and the drill motor is in "Drill" mode.

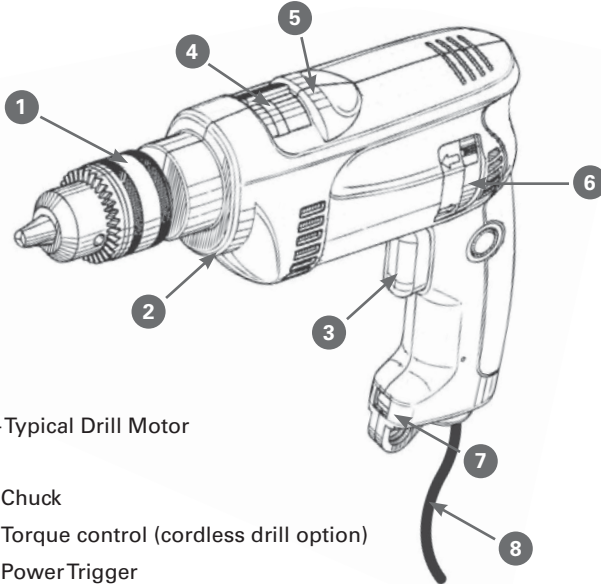

Figure 3-2 - Typical Drill Motor

1. Chuck
2. Torque control (cordless drill option)
3. Power Trigger
4. Speed Controller (optional)
5. Drill/Hammer Function Selector (optional)
6. Direction Selector
7. Battery Pack (cordless)
8. Power Cord

## WARNING

USE ONLY CORDLESS OR DOUBLE INSULATED CORDED DRILL MOTORS. DISCONTINUE THE USE OF THE DRILL IF A FAULT IS DETECTED. ENSURE THE DRILL MOTOR IS IN "DRILL" MODE AND SET TO THE APPROPRIATE TORQUE SETTING.

## 3.3 Machine Operation

### General

When the platform reaches the bottom of its travel, the overload clutch creates a ratcheting or buzzing noise, indicating that the machine has reached the fully lowered position.

### CAUTION

**BE SURE TO MAINTAIN A FIRM GRIP ON THE DRILL AT ALL TIMES DURING OPERATION.**

The machine is fitted with a drive shaft brake to prevent motion of the platform not initiated by the operator.

Before operating the machine, be sure the platform is fully lowered and all four (4) outriggers are properly installed (See Figure 3-3). Be sure the machine is level and on a surface capable of supporting the intended load.

### WARNING

**IN THE EVENT THAT THE CLIMBING UNIT FAILS TO ELEVATE AFTER THE OUTRIGGERS HAVE BEEN PROPERLY INSTALLED AND STABILIZED, THE MACHINE IS NOT WORKING PROPERLY AND MUST NOT BE USED UNTIL IT IS INSPECTED AND REPAIRED BY A QUALIFIED PERSON.**

**NOTE:** *Do not attempt to enter or exit the platform unless it is fully lowered.*

## 3.4 Machine Setup

Because the ReechCraft PowerLift is a modular operator assembled machine, the platform, each outrigger and mast section can be removed to reduce weight as the situation requires.

**NOTE:** For the purposes of this section, it is assumed that the machine is in it's fully stowed configuration.

### Getting Started

1. Place the machine on a firm, stationary surface capable of supporting the intended load directly under the desired work area.
2. Connect to an appropriate power source. AC: connect to a grounded 15A AC power supply. Be careful the extension cord remains slack at maximum height and does not become entangled in the machine which may lead to electrical shock or instability.
3. Install front and rear outriggers in their designated positions. Using the drill and hex driver, level the chassis by adjusting each of the leveling jacks, until the bubble level is centered. (See Figure 3-3)

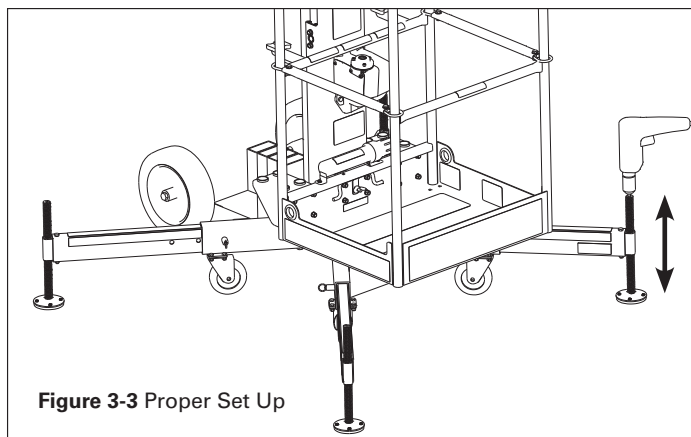

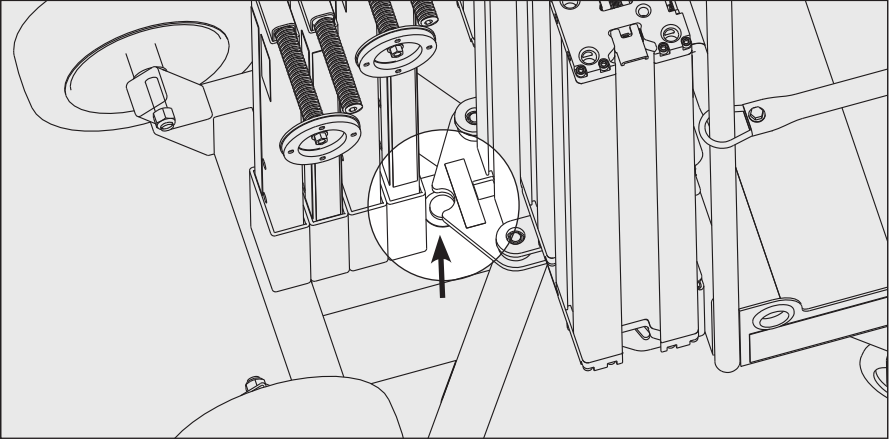

Figure 3-4 Bubble Level

## WARNING

**DO NOT USE MACHINE IF CHASSIS CANNOT BE LEVELED**

### Elevating

Make sure the pre-start inspection has been completed and the machine is safe to use and the chassis is level and stable with all four outriggers bearing weight.

Move the direction selector so the drill motor is in the forward (clockwise) position.

Hold the drill motor handle firmly, push down lightly to automatically disengage the drive shaft brake and squeeze the trigger to elevate.

Stop using the drill motor if any part of it becomes excessively hot. Wait until the drill motor has cooled down before continuing operation.

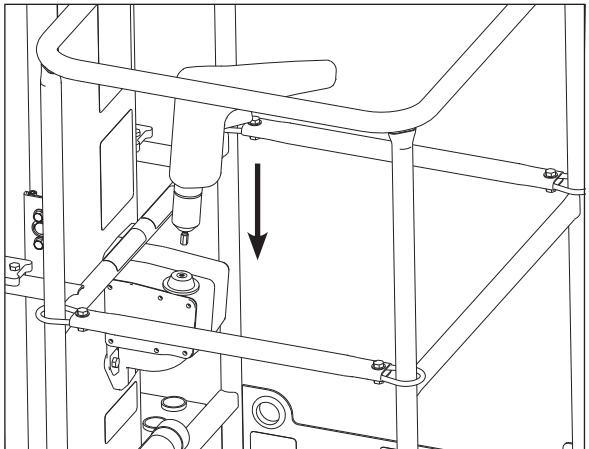

Figure 3-5 Drill Motor Operation / Elevating

## Joining Mast Sections

### CAUTION

**DO NOT DROP MAST SECTIONS. ALWAYS MAINTAIN A FIRM GRIP WHEN HANDLING**

**Figure 3-6** Joining Mast Sections

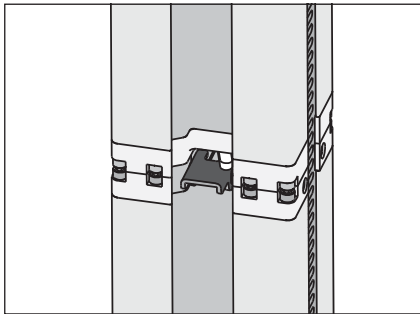

- 1.** Stack the mast ensuring that the track is facing toward the platform.

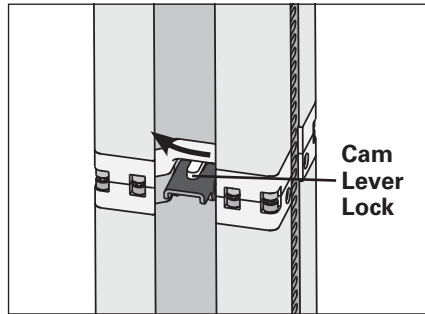

- 2.** Rotate the cam lever lock until it stops in the center position.

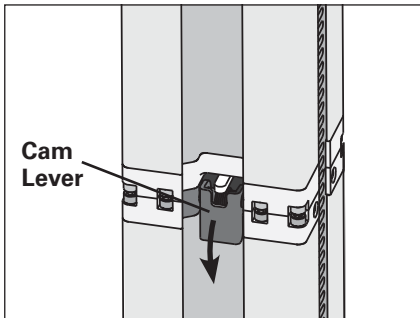

- 3.** Press both cam levers down and in at the same time.

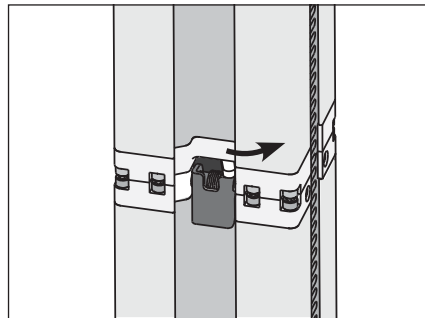

- 4.** With the cam lever in the down position, be sure the cam lever lock springs automatically into the locked position.



## Separating Mast Sections

Figure 3-7 Separating Mast Sections

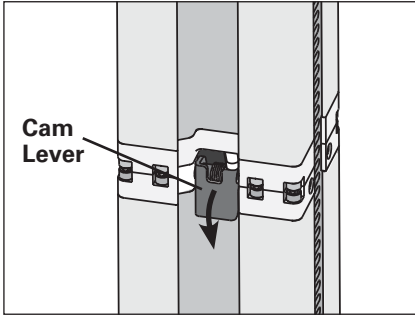

1. Press both cam levers inward to allow the cam lever lock to rotate freely.

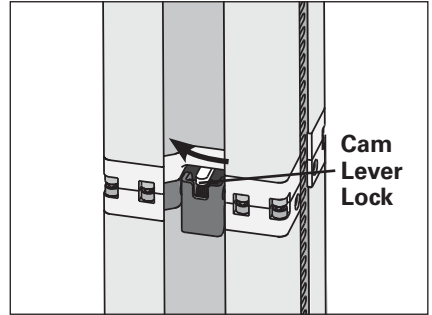

2. Rotate the cam lever lock until it stops in the center position.

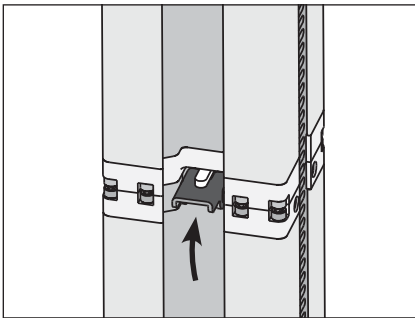

3. Release the cam levers to the open position.

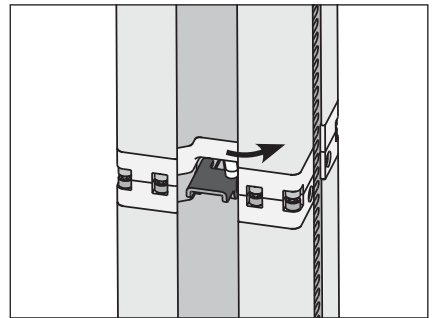

4. Carefully return to the stowed position.

Elevate the climbing unit approximately 3 in. (80 mm) past the top of the mast and carefully remove the mast section from its stowed position.

## Unpowered Decent

The platform Manual Decent Crank (See Figure 2-5) is provided to:

Allow the machine operator to lower the platform in the event that the drill motor loses power or contains insufficient power to lower the platform.

*For emergency operation please see section 4 - Emergency Procedures.*

## 3.5 Maneuvering & Transport

### General

The machine may be manually maneuvered or transported in a vehicle disassembled or fully stowed.



**DO NOT ATTEMPT TO TRANSPORT OR MOVE MACHINE UNLESS THE PLATFORM IS FULLY LOWERED. DO NOT MOVE THE MACHINE WITH PERSONNEL IN THE PLATFORM.**

The machine may be moved around a worksite using the following methods:

- Fully assembled, pushed around the floor using the casters.
- Disassembled, with each major component carried separately.

There are two ways to move the assembled machine:

### Upright Maneuvering

- The machine can be pushed or pulled around using the swivel casters.
- The floor is required to be smooth, level and dry.
- All outriggers must be installed corresponding to the number of masts, and elevated temporarily during maneuvering only. (See Figure 3-4)
- There can be no significant weight on the machine while it is being rolled around.
- Be sure there are no overhead or ground obstructions or hazards

**NOTE:** *Be sure the swivel casters are in their unlocked position and free of debris on the wheel or in the mechanism.*

### Tilted Over Maneuvering

- For increased control, lock the rear casters before tilting back.
- Ensure that control of the machine will be maintained during tilt back and during transport.
- Be sure to maintain a firm grasp of the handle at all times during transport.
- Familiarize yourself with the terrain and identify and avoid any overhead or ground hazards before tilting back and transporting.

The machine can be tilted over and maneuvered as shown in Figure 3-8.

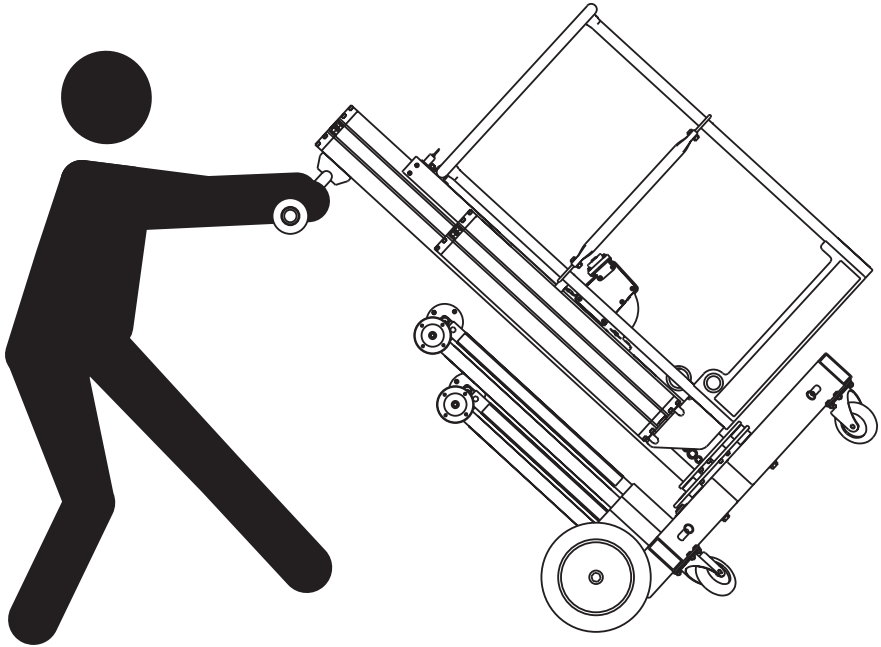

Figure 3-8 Maneuvering when tilted back

**NOTE:** *Ensure platform is empty before tilting back.*

**⚠ CAUTION**

**ONLY ATTEMPT TO TILT THE UNIT BACK, OR RETURN TILTED UNIT TO THE UPRIGHT POSITION ON A FLAT AND LEVEL SURFACE, CLEAR OF ANY PERSONNEL. ENSURE A FIRM GRIP WITH TWO HANDS ON THE HANDLE AND ENSURE WEIGHT IS DISTRIBUTED TO AVOID THE USER OR THE MACHINE BEING THROWN BY THE MOVING WEIGHT OF THE MACHINE.**

**⚠ WARNING**

**TAKE PRECAUTIONS TO AVOID MANUAL HANDLING INJURIES. USE PROPER LIFTING TECHNIQUES: BEND AT THE KNEES ONLY, NEVER TWIST YOUR BACK WHEN HOLDING OR CARRYING A LOAD, AND/OR GET HELP. ONLY CARRY ONE COMPONENT AT A TIME.**

## Parking and Storage

- Move machine to a dry, well protected and well ventilated area out of direct sunlight.
- Ensure the platform is fully lowered.
- If necessary, remove the drill motor to prevent unauthorized use.
- Ensure at least two of the swivel casters are in the fully locked position.

### NOTICE

**DO NOT STORE IN LOCATIONS WHERE THE MACHINE MAY ACCUMULATE ICE, GREASE OR AIRBORNE DEBRIS.**

## Vehicle Transport

When transporting the machine by vehicle, it should be disassembled into its major components and each component secured separately. Restrain each component of the machine securely during transport.

When transported fully stowed, the machine should be completely and securely restrained to eliminate any shifting or excessive movement.

### NOTICE

**USE OF EXCESSIVE FORCE WHEN SECURING MACHINE CAN CAUSE DAMAGE TO THE MACHINE.**

Secure the machine to the transport vehicle with adequately rated ropes or straps. Do not over stress such devices and place a buffer between the device and any part of the machine.

# SECTION 4

## EMERGENCY PROCEDURES

### 4.1 General Information

This section explains the steps to be taken in the case of an emergency situation during operation.

#### Manual Descent Crank

The platform manual descent crank is provided to:

- Allow the platform operator to lower the platform in the event the corded drill loses power or the batteries of the cordless drill run out of sufficient charge to lower the platform.

### NOTICE

**THE CRANK IS DESIGNED FOR MANUAL DESCENT IN CASE OF LOSS OF POWER ONLY. IT MUST NOT BE USED TO ELEVATE THE PLATFORM OR FOR GENERAL OPERATIONS.**

### WARNING

**IF THE BATTERY OF THE DRILL IS DISCHARGED OR IF THERE IS A LOSS OF POWER WHILE THE UNIT IS ELEVATED, DO NOT CLIMB OUT OF THE PLATFORM. USE THE MANUAL DESCENT CRANK TO LOWER THE PLATFORM.**

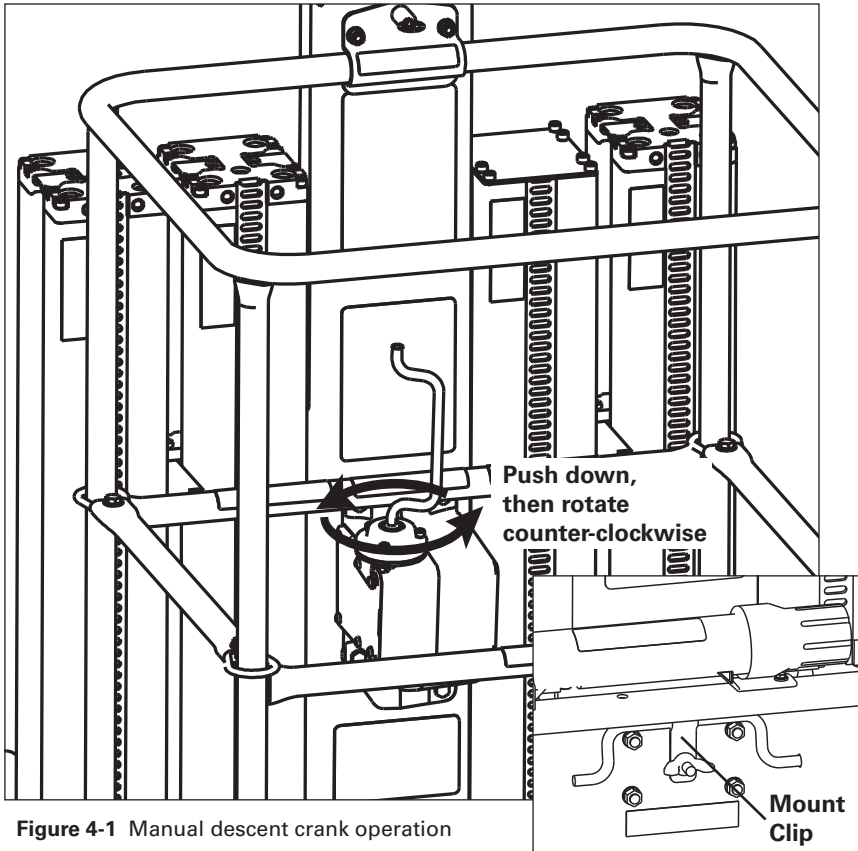

Figure 4-1 Manual descent crank operation

## Discharged Battery or Loss of Power

1. If the battery of the drill should run out of charge or if there is a loss of power to the corded drill before the platform has fully descended.
2. Remove the drill and place it inside the platform.
3. Remove the manual descent crank from the mounting clip inside the platform.
4. Engage the drive shaft with the manual crank.
5. Push down on the top of the handle to disengage the drive shaft brake and wind counterclockwise until the platform lowers fully.  
(See Figure 4-1)

## Operator Unable to Control the Machine

If the platform operator is pinned, trapped or unable to operate or control the machine other personnel should deploy the Emergency Retrieval System to lower the platform and rescue the operator. (see Figure 4-2)

Figure 4-2 Emergency Retraction System

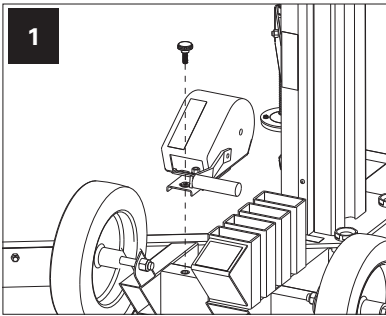

1  
Remove retraction winch from chassis.

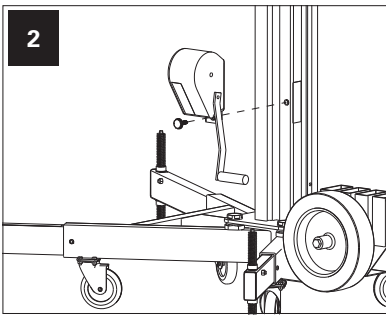

2  
Attach winch to base mast and unwind strap.

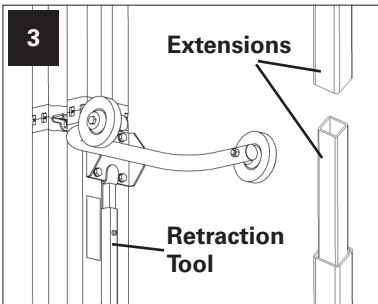

3  
Remove and extend retraction tool.  
Add extensions to the retraction tool.

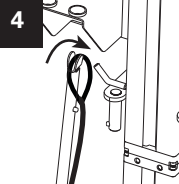
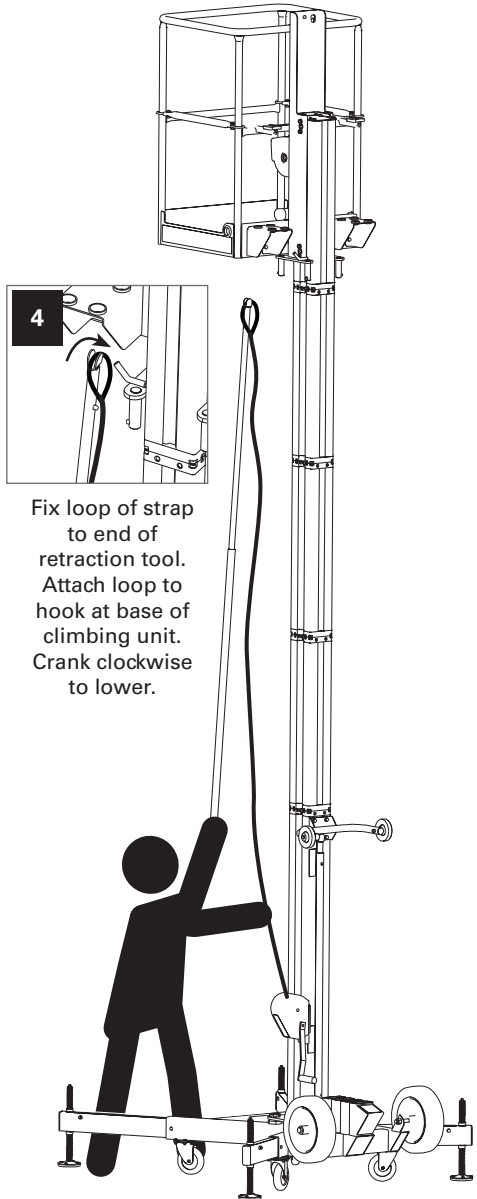

4  
Fix loop of strap to end of retraction tool. Attach loop to hook at base of climbing unit. Crank clockwise to lower.

## Platform Caught Overhead

If the platform becomes jammed or snagged in overhead structures or equipment, rescue the platform occupant prior to freeing the machine.

## 4.2 Incident Notification

ReechCraft, Inc must be notified immediately of any incident involving a ReechCraft product. Even if no injury or property damage is evident, the factory should be contacted by telephone and provided with the necessary details.

Contact:

### Technical Safety and Engineering Department

845 34th St N  
Fargo, ND 58102

### In USA

Toll Free: 888-600-6160

### Outside USA

Phone: 701-280-5900  
E-mail: [customer.service@reechcraft.com](mailto:customer.service@reechcraft.com)

Failure to notify the manufacturer of an incident involving a ReechCraft PowerLift product within 48 hours of such an occurrence may void any warranty consideration on that particular machine.

## NOTICE

**FOLLOWING ANY ACCIDENT, THOROUGHLY INSPECT THE MACHINE AND TEST ALL FUNCTIONS. DO NOT ELEVATE PLATFORM UNTIL YOU ARE SURE THAT ALL DAMAGE HAS BEEN REPAIRED IF REQUIRED, AND THAT ALL CONTROLS ARE OPERATING CORRECTLY.**



# SECTION 5 GENERAL SPECIFICATIONS

## 5.1 Introduction

This section of the manual provides operating specifications and information necessary for the proper maintenance of this machine.

## 5.2 Decal Contents & Location

CHASSIS / BASE MAST		
No.	Type	ReechCraft Part Number
A1	Bubble Level	4026021
A2	Emergency Retraction Procedure	4026015
A3	Retraction Winch Mount	4026025
A4	Emergency Retraction Winch	4026026
A5	Strap Connector	4026586

CLIMBING UNIT		
No.	Type	ReechCraft Part Number
B1	Manufacturer Nameplate	4026197
B2	Read Manual / Tip Hazard	4026404
B3	Serial Number	

PLATFORM		
No.	Type	ReechCraft Part Number
C1	Load Capacity	4022998
C2	Crush Hazard	4026003
C3	Read Manual	4026005
C4	Platform Step Warning / Brand	4022976
C5	Platform Latch Release	4026001
C6	Manual Descent Crank	4026011
C7	Manual	4026199
C8	Anchor Point/Cord Throughway	4022999
C9	Drive Shaft Brake Release	4026004
C10	Front Logo	4022977
C11	Lift/Lower Direction	4026319

OUTRIGGER		
No.	Type	ReechCraft Part Number
D1	Step Warning (Front)	4022876
D2	Step Warning (Rear)	4022874

**Table 5-1** Decal Contents and Location (See Figure 5-4)

## GENERAL SPECIFICATIONS

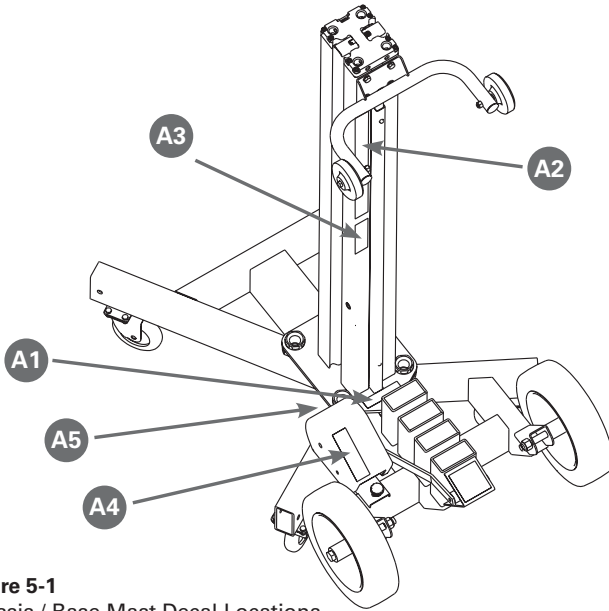

**Figure 5-1**  
Chassis / Base Mast Decal Locations

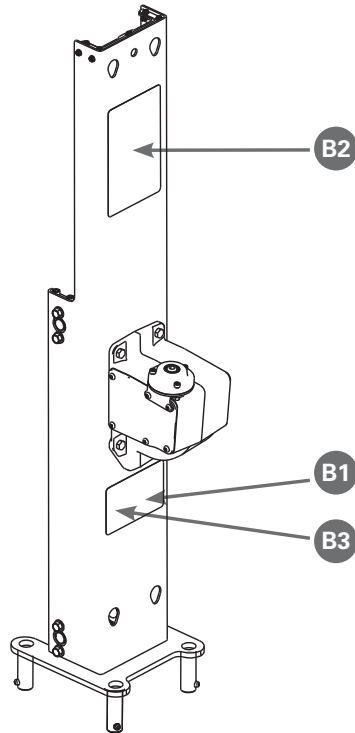

**Figure 5-2**  
Climbing Unit Decal Locations

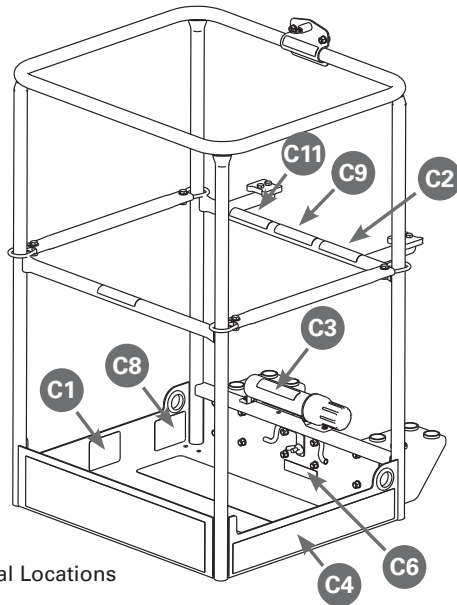
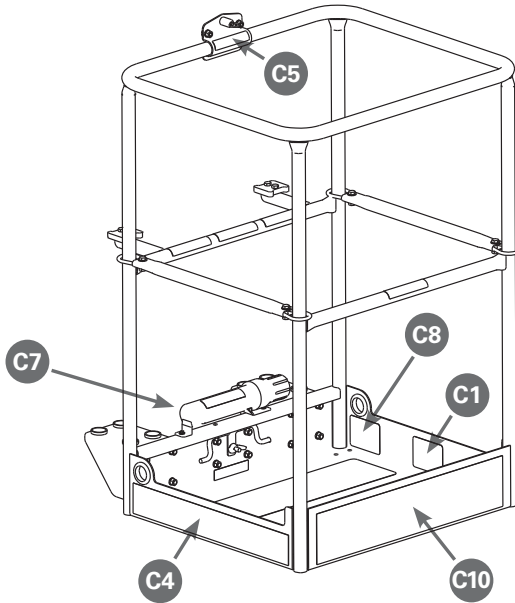
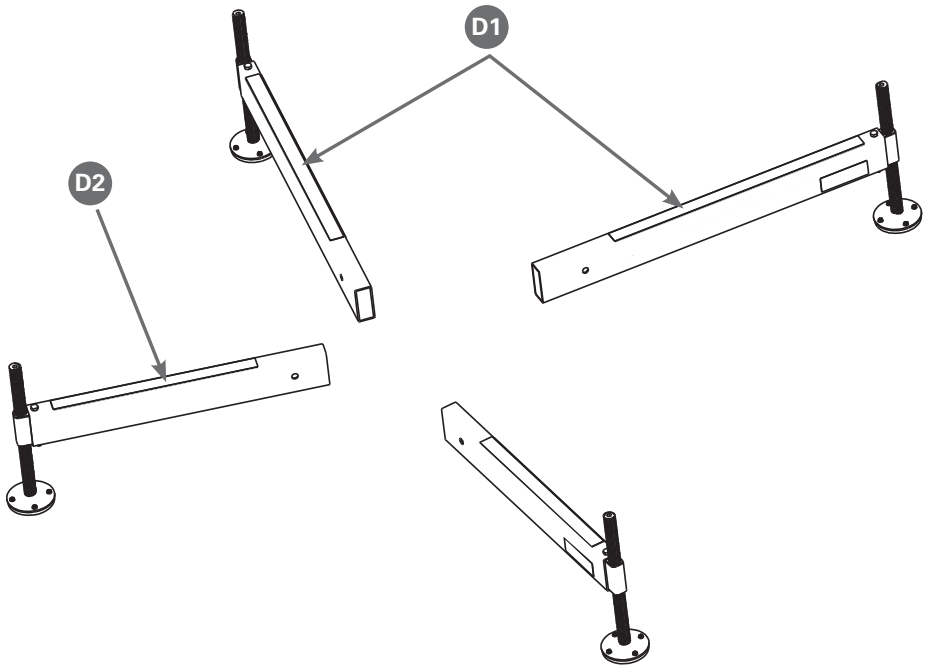

Figure 5-3 Platform Decal Locations

Figure 5-4 Outrigger Decal Locations



## 5.3 Specifications

### Machine Specifications

	SPECIFICATION	PL60
	Platform Capacity	350 lbs (159 kg)
	Power Source	AC or DC Drill
	Rated Horizontal Force	52.5 lbs (234 N)
	Machine Weight	310 lbs (141 kg)
	Swivel / Lockable Caster Diameter	127 mm
	Platform Size (L x W)	26 in. x 30 in. (660 mm x 762 mm)
	Mast Section Weight	28.5 lbs (12.9 kg)
	Rear Outrigger Weight	9.3 lbs (4.2 kg)
	Front Outrigger Weight	10.6 lbs (4.8 kg)
	Flat Free Transport Wheels	12 in. x 3.5 in. (305 mm x 89 mm)
	Drive	Worm Drive with Integrated Drive Gear & Brake
A	Stowed Length	53.4 in. (1356 mm)
B	Stowed Width	30 in. (762 mm)
C	Stowed Height	56.6 in. (1741 mm)
D	Minimum Platform Height	12.9 in. (329 mm)
E	Outrigger Footprint Width	67.1 in. (1705 mm)
F	Outrigger Footprint Length	64.4 in. (1635 mm)
G	Distance from Wall Side	18.5 in. (471mm)
H	Distance from Wall Front	10.3 in. (261 mm)
I	Erected Mast Height	21.7 (6.60 m)
J	Max Platform Height	19.5 ft (5.94 m)
	Max Working Height*	25.5 ft (7.77 m)

**Table 5-2** Machine Specifications

\* Based on Platform Height plus 6 ft

Figure 5-5 Machine Specifications

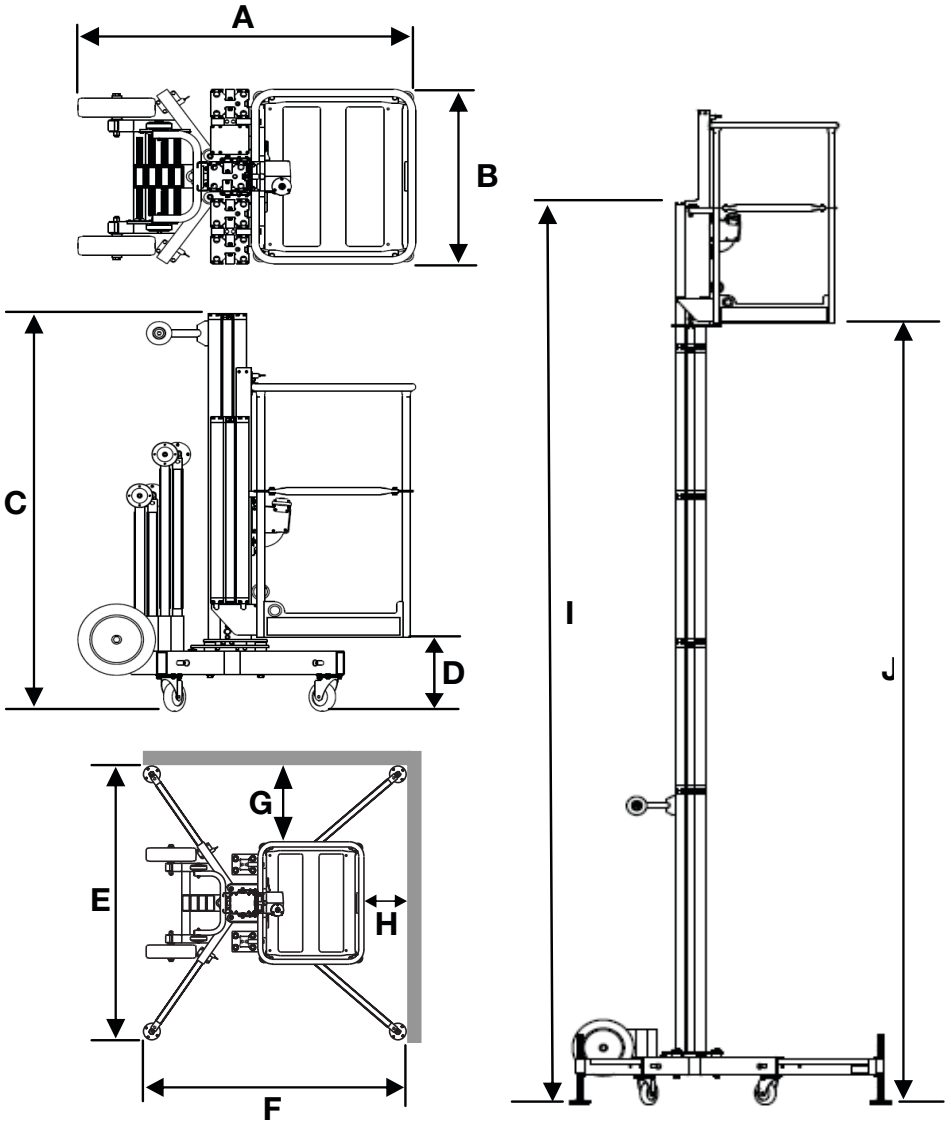

## 6.1 Maintenance Safety Precautions

### General

This section contains general safety precautions which must be observed during maintenance of the machine. It is important that maintenance personnel heed these warnings to avoid possible injury to themselves or others. A maintenance program must be established by a competent person and followed to ensure the machine is in safe operating condition.

Due to our commitment to continuous improvement, ReechCraft reserves the right to make specification changes without prior notification. Contact ReechCraft for updated information.



**MODIFICATION OF THE MACHINE WITHOUT THE MANUFACTURERS APPROVAL IS A PROHIBITED PRACTICE AND A DIRECT SAFETY VIOLATION.**

Your safety and the safety of others is the primary concern when performing service and maintenance on the machine. Always be conscious of moving parts and pinch points. Never leave an object in an unstable or unsupported position.



**SINCE THE MANUFACTURER HAS NO DIRECT CONTROL OVER THE FIELD SERVICE AND MAINTENANCE OF THE MACHINE, SAFETY IS THE RESPONSIBILITY OF THE OWNER/OPERATOR.**

## Maintenance Safety



**FAILURE TO COMPLY WITH THE SAFETY PRECAUTIONS LISTED IN THIS SECTION COULD RESULT IN MACHINE DAMAGE, PERSONAL INJURY OR DEATH, AND IS A SAFETY VIOLATION**

- REMOVE ALL RINGS, WATCHES, AND JEWELRY WHEN PERFORMING ANY MAINTENANCE.
- DO NOT WEAR LONG HAIR UNRESTRAINED, LOOSE-FITTING CLOTHING OR NECKTIES WHICH MAY BECOME CAUGHT OR ENTANGLED IN THE MACHINE
- OBSERVE, UNDERSTAND AND OBEY ALL DANGER, WARNING, CAUTION AND OTHER INSTRUCTIONS ON THE MACHINE AND IN OPERATORS MANUAL.
- KEEP STANDING SURFACES AND HAND HOLDS FREE OF GREASE, WATER, OIL, ETC.
- NEVER WORK UNDER AN ELEVATED PLATFORM UNTIL THE PLATFORM HAS BEEN SAFELY RESTRAINED FROM ANY MOVEMENT.
- BEFORE MAKING ANY ADJUSTMENTS OR PERFORMING ANY OTHER MAINTENANCE ON THE MACHINE, SHUT OFF ALL POWER.
- KEEP ALL OUTRIGGERS AND ATTACHMENTS STOWED IN THEIR PROPER PLACE.
- USE ONLY APPROVED, NONFLAMMABLE CLEANING SOLVENTS.



## 6.2 Machine Preparation, Inspection & Maintenance

### General

This section provides the necessary information needed by those personnel that are responsible to place the machine in operational readiness and maintain its safe operating condition. To ensure maximum service life and safe operation, be sure that all inspections and maintenance has been completed before placing the machine into service.

### Preparation, Inspection and Maintenance

It is important to establish a comprehensive inspection and preventative maintenance program. Table 2-1 outlines the periodic machine inspection and maintenance recommended by ReechCraft. Consult your local, regional or national regulations for further requirements. Note: the frequency of inspections must increase as environment and frequency of use requires.

### Pre-Start Inspection

It is the operators responsibility to perform a Pre-Start Inspection of the machine prior to use. Reference Section 2 in this manual for Pre-Start Inspection procedures.

This manual must be read and understood in its entirety prior to performing a Pre-Start Inspection.

### Frequent and Pre-Delivery Inspection

The Frequent Inspection and Pre-Delivery Inspection shall be performed by a competent person or a qualified mechanic.

The Frequent Inspection and Pre-Delivery Inspection procedures are performed in the same way but at different times. The Pre-Delivery Inspection shall be performed prior to each sale, lease, or rental delivery. The Frequent Inspection shall be performed on each machine in service for 3 months; out of service for more than 3 months; or when purchased used. The frequency of this inspection must increase as environment and frequency of use requires.

Reference the appropriate areas of this manual for service and maintenance procedures.

## Annual Machine Inspection

The Annual Machine Inspection must be performed by a competent person or a qualified mechanic on an annual basis, no later than 13 months from the date of the prior Annual Machine Inspection.

Reference the Service and Maintenance Sections of this manual and appropriate inspection form to complete this inspection.

## 5 Year Machine Inspection and Track Replacement

The Mast Coupling Pins, Cam Locks, Track and Climbing Unit must be inspected and the track replaced by an authorized ReechCraft Service Center when:

- The track is worn beyond specification (5 mm) (See Figure 6-1)
- The track is damaged, bent or corroded.

In conjunction with specified inspections, maintenance shall be performed by a competent person or a qualified mechanic.

## 6.3 Preventive Maintenance & Inspection Schedule

The preventive maintenance and inspection checks are listed and defined in the following table. The table is divided into two parts: "AREA" and "INTERVAL". The component or function to be inspected are listed in the AREA column and the interval at which time they are to be inspected are listed in the INTERVAL column.

**NOTE:** *The checks and services listed in this schedule are not intended to take the place of any local or regional regulations that may pertain to this type of equipment nor should the list be considered as all inclusive. Variances in interval times may occur due to the environment the machine is subjected to.*

### Inspection and Maintenance Codes:

1. Check for proper and secure installation
2. No gouges, excessive wear, or dents showing
3. Visually inspect for excessive wear, damage, cracks or distortion
4. Check for cracked or broken welds
5. Check area is clean and free of debris
6. Check for proper adjustment
7. Check for proper operation
8. Check for proper spring back
9. Check for signs of leakage
10. Check for proper tolerances
11. Check for proper specifications
12. Verify
13. Perform
14. Replace
15. Inspect per Operator's Safety Manual

Area	Interval			
	Pre-start Inspection	Pre-Delivery or Frequent Inspection	Annual (yearly) Inspection	5 Year Inspection
	Prior to use each day	Prior to each sale, lease or delivery; in service for 3 months or more; purchased used	Perform no later than 13 months from the date of prior inspection	When track is worn or no more than 5 years from first use
Mast Sections	1,3,5	1,2,3,5,	1,2,3,5	
Interlock	5	5,7	5,6,7	
Track	3	3	3	15
Climbing Unit	5	3,5	1,3,5,7	
Gearbox	3,7,9	3,7,9	1,3,7,9	
Manual Crank	1	1,12	1,3,12	
Climbing Unit	7	1,7	1,3,5,10,7	
Platform	1,4,5	1,4,5	1,3,4,5,7	
Platform Latch	1,4,7,8	1,3,4,6,7,8	1,3,4,6,7,8	
Chassis	3,4,5	3,4,5	3,4,5	
Outriggers	1,5,8	1,3,5,7,8	1,3,5,7,8	
Bubble Level	1,5,7	1,5,7	1,5,7	
Casters	3,7	3,4,7	3,4,7	
Rough Terrain Wheels	3,7	3,4,7	3,4,7	
Drill	7,11	7,11	7,11	
Drive Shaft Brake	1,3,7,8	1,3,7,8	1,3,7,8	
Manual in Storage Container	12	12	12	
Decals installed and secure	12	12	12	
No unauthorized modifications	12	12	12	
Fasteners and pins	1,3	1,3	1,3	
Function test	13	13	13	
		13 (Delivery)	13	

Table 6-1 Preventive Maintenance &amp; Inspection Schedule

## 6.4 Servicing & Maintenance Guidelines

### General

The following information is provided to assist you in the use and application of service and maintenance procedures contained in this chapter. **NOTE:** *Please refer to Service and Parts Manual for additional information.*



**WHEN AN ABNORMAL CONDITION IS NOTED AND PROCEDURES CONTAINED WITHIN THIS MANUAL DO NOT SPECIFICALLY RELATE TO THE NOTED IRREGULARITY, USE OF THE MACHINE SHOULD BE STOPPED AND A QUALIFIED MECHANIC WITH PROPER KNOWLEDGE SHOULD CORRECT THE IRREGULARITY BEFORE WORK IS RESUMED.**

### Safety and Workmanship

Your safety, and that of others, is the first consideration when engaging in the maintenance of equipment. Always be conscious of moving components and pinch points. Do not allow heavy objects to rest in an unstable position. When raising a portion of the machine, ensure that adequate support is provided.

### Cleanliness

The single most important item in preserving the long service life of a machine is to keep foreign materials out of the vital components. Reasonable precautions have been taken to safeguard against this. However, these areas must be maintained on a scheduled basis in order to preserve proper function of the machine.

### Component Disassembly and Reassembly

When disassembling or reassembling a component, complete the procedural steps in sequence. Do not partially disassemble or reassemble one part and then start another. Always recheck your work to assure that nothing has been overlooked. Do not make any adjustments, other than those recommended, without obtaining proper approval.

## 6.5 Decal Replacement

All decals must be mounted to the machine as specified and clearly legible.

*Please see Figure 5-1 to Figure 5-4 and refer to table 5-1 for positions and ReechCraft part numbers.*

To replace a damaged decal, first remove it completely without damaging the underlying surface.

Remove any remaining adhesive with a suitable solvent. Test the solvent on an inconspicuous area first to ensure it does not mark or damage the surface finish.

### NOTICE

**SURFACE DAMAGE COULD RESULT IN CORROSION AND STRUCTURAL DAMAGE.**

Before applying the new decal, ensure the surface is clean and dry.

Remove the backing paper, apply the decal along one edge then seal it gently and evenly.

If there are any air bubbles, work them gently towards the edge with a clean cloth.

Pressure sensitive adhesives reach full strength after several days.

## 6.6 Mast Track Inspection Procedure

### NOTICE

**MAST SECTIONS SHOULD BE INSPECTED EVERY 3 MONTHS OR MORE FREQUENTLY DEPENDING ON ENVIRONMENT**

The MastTrack sections should be inspected more frequently if used in a harsh environment or high duty cycle applications. Inspection should be more frequent as they approach the end of their useful lives. The periodic inspection shall cover all mast track sections on the machine.

MastTrack sections must be replaced by an Authorized ReechCraft Service Center.

Conditions such as the following shall be sufficient reason for questioning continued use of the machine or increasing the frequency of inspection.

## 1. Mast Track Wear

Check that the track is not worn (1.88 in. (5 mm) tooth remaining) and that the galvanized surface is in good condition and no corrosion or excessive rust is present.

## 2. Mast Track Misalignment

Be sure that the track is aligned properly at the joint location. If the track is bent or damaged in any way, it must be replaced by a qualified mechanic before machine use may resume.

## 3. Mast Connector Wear

MastTrack misalignment may be due to worn or damaged coupling pins located in the Mast Connector. If any part of the connector is worn or and excessively loose when properly coupled and locked together, it must be replaced before machine use may resume.

Figure 6-1 Mast /Track Alignment

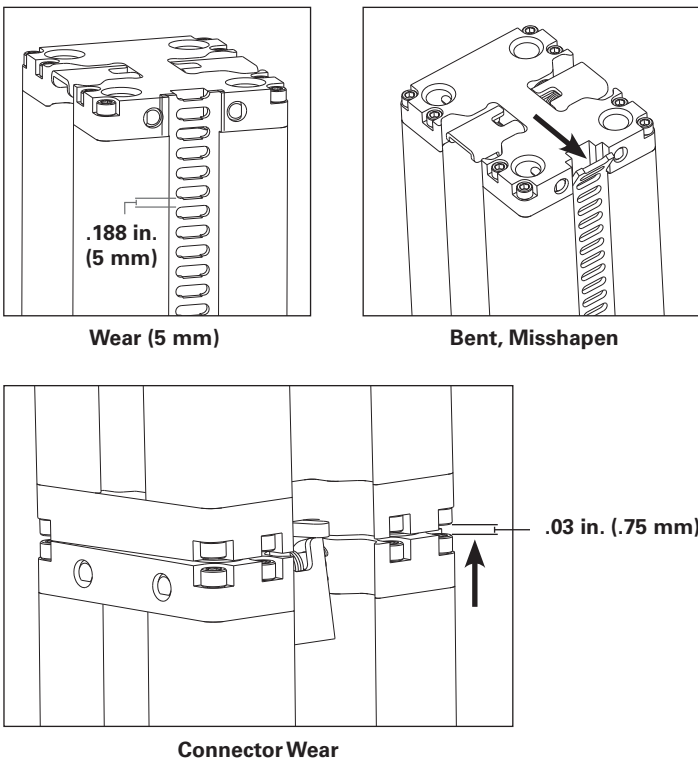





### 7.1 General

This section contains troubleshooting information to be used for locating and correcting most of the operating problems which may develop in the machine. If a problem should develop which is not presented in this section, qualified guidance should be obtained before proceeding with any maintenance.

#### Troubleshooting Information

The troubleshooting procedures applicable to the product are listed and defined in Table 7-1, Troubleshooting Guide.

Each malfunction within an individual group or system is followed by a listing of probable causes which will enable the determination of the applicable corrective action. The probable causes and corrective action should, where possible, be checked in the order listed in the tables.

It should be noted that there is no substitute for thorough knowledge of the equipment and related systems.

It should be recognized that the majority of the problems arising in the machine will be centered in the power system. For this reason, every effort has been made to ensure that all likely problems in these areas are given the fullest possible treatment. In the remaining machine groups, only those problems which are symptomatic of greater problems which have more than one probable cause and remedy are included. This means that problems for which the probable cause and remedy may be immediately obvious are not listed in this section.

## TROUBLESHOOTING

TROUBLE	PROBABLE CAUSE	REMEDY
<b>Platform does not lift up from the fully lowered position - Drill motor starts</b>		
	One or more interlocks are engaged	Check to be sure all four outriggers are properly installed extended and stable.
	Overload clutch is slipping	Be sure the rated load of 350 lbs (159 kg) is not exceeded and that the platform is free and clear of any obstruction or interference.
	One or more interlock pins are wedged in the locked position	Lower platform to the fully lowered position to relieve pressure, ensure all leveling jacks are stable and bearing equal weight.
<b>Platform will not move when in elevated position - Drill motor starts</b>		
	Intermediate mast section is installed backwards with the track section facing away from the platform	Lower the platform and reinstall the mast section with the track section facing the platform.
	One or more of the connector lock levers are in the open position interfering with the rollers	Lower the platform to expose the last section of mast that was installed and check to be sure both levers are completely engaged and locked in position.
	The maximum height has been attained causing interference with the top termination plate	No remedy. System is functioning properly.
<b>Platform moves sluggishly</b>		
	Drive Shaft brake is engaged	Depress the input shaft slightly before applying power to release the brake.
	Drill battery not fully charged	Charge battery
	Drill has insufficient power or RPM	Be sure the drill contains a motor of 7 amps and 1200 RPM or more.
<b>Machine does not wheel properly</b>		
	One or more castors are in the locked position	Unlock the castor
	One or more castors are damaged	Replace the damaged castor
<b>Climbing Unit jumps or lurches while elevating</b>		
	Track is damaged and missing teeth	Replace the track section*

\*Performed by Authorized ReechCraft Service Center

**Figure 7-1** Troubleshooting Guide



ReechCraft.  
***PowerLiFT***<sup>™</sup>

**ReechCraft Inc.**  
845 34th St N  
Fargo, ND 58102  
**888.600.6160**

[www.reechcraft.com/powerlift](http://www.reechcraft.com/powerlift)